

**NEW**

# VigiLED

Surface Mount or Bracket Mount LED Directional



Fleet



Cars



Delivery Vehicles



Refuse Trucks



Large Vehicles



Motorway Maintenance



Recovery



Utility Vehicles



Road Safety

- Triple flash
- Ultra bright LEDs
- Long life – 100,000 hour rated LEDs
- Synchronous or alternate flash
- Clear lens with coloured LEDs
- Available in amber, blue & red
- Ultra low power consumption
- Supplied with accessories for bracket or surface mount
- Fully sealed electronics – no need for separate power supply/control unit
- Weatherproof to IP67
- Dual Voltage 12/24V



delta design  
a division of NICOTECH Limited

*.. simply brilliant*

# VigiLED *Surface Mount or Bracket Mount LED Directional*

## technical specification:



MODEL	COLOUR	PART NO.	TYPE	VOLTAGE RANGE	LIGHT OUTPUT EFFECTIVE cd	CURRENT CONSUMPTION (mA)		FLASH RATE (NOMINAL)	WEIGHT (Gms)
						@12V	@24V		
DR4TXDV/LED	AMBER	497022	TRIPLE FLASH	10 – 30 Vdc	>80cd	120	65	75/MIN	170
DR4TXDV/LED	BLUE	497024	TRIPLE FLASH	10 – 30 Vdc	>76cd	120	65	75/MIN	170
DR4TXDV/LED	RED	497023	TRIPLE FLASH	10 – 30 Vdc	>80cd	120	65	75/MIN	170

Operating temperature: -20°C to +55°C. Certified to the EMC Directive 95/54

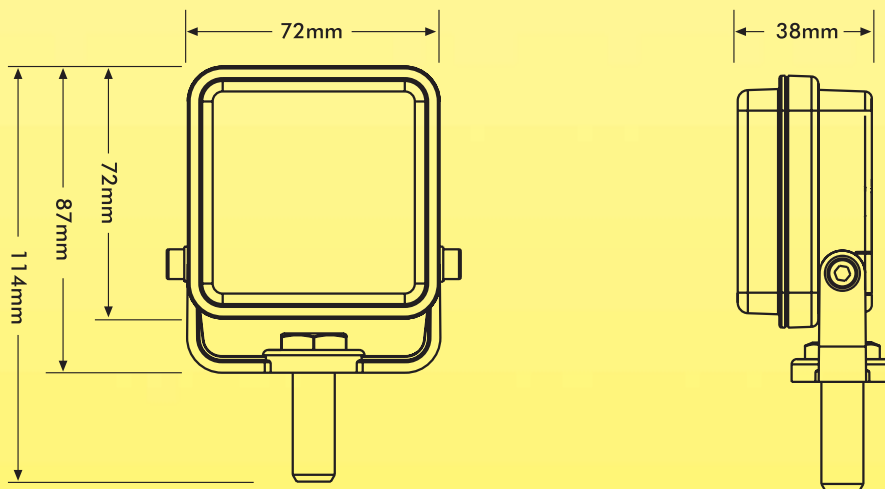

## dimensions:



## materials:

-  Polycarbonate Lens
-  Polycarbonate Base

## colours:

-  Amber LEDs
-  Blue LEDs
-  Red LEDs



Primrose Hill, Kings Langley,  
Herts WD4 8ST, England.

Tel: (U.K.) 01923 272850  
(Int.) +44 1923 272850

Fax: (U.K.) 01923 260167  
(Int.) +44 1923 260167

E-mail: [sales@deltadesign.co.uk](mailto:sales@deltadesign.co.uk)  
Web: <http://www.deltadesign.co.uk>

ISO 9001 CERTIFIED ORGANISATION



United Registrar of Systems Cert No. 11211

Your Delta Design distributor:

All specifications are nominal and subject to change without notice.