

WHELEN[®]

ENGINEERING COMPANY INC.

Route 145, Winthrop Road,
Chester, Connecticut 06412

Phone: (860) 526-9504

Fax: (860) 526-4078

Internet: www.whelen.com

Sales e-mail: autosale@whelen.com

Canadian Sales e-mail: autocan@whelen.com

Customer Service e-mail: custserv@whelen.com

Installation Guide: UHF2150A High Beam Flasher

Automotive: Flashers

IMPORTANT NOTES!

- The use of a flashing headlight system may be regulated by state, county, or municipal authorities. It is the responsibility of the end user to comply with these regulations.
- It is the responsibility of the installer to make sure that the high beam and low beam filaments of a dual filament bulb never come on together. The excessive heat generated by this condition will melt the headlight assembly. The brown disable wire may have to be connected to the parking lights or the low beams to override the flasher and prevent both filaments from coming on simultaneously.
- The installation of a headlight flasher system requires a modification to the standard headlight wiring harness. This modification may effect the warranty of your vehicle. It is the responsibility of the end user to verify the warranty conditions with the vehicle manufacturer. Also, the use of a headlight flasher may shorten the high beam bulb life.
- Before attempting the installation of the UHF2150A headlight flasher, thoroughly read and understand instructions and steps shown below!
- Disconnect the battery from the electrical system before attempting any part of this installation!
- All customer supplied wires that connect to the positive terminal of the battery must be sized to supply at least 125% of the maximum operating current and FUSED at the battery to carry the load. **DO NOT USE CIRCUIT BREAKERS WITH THIS PRODUCT!**

Installation

There are two different switching methods used to activate the headlights/parking lights in a motor vehicle; **Positive-Side** Switching and **Ground-Side** Switching. For example, the headlights may use Positive-Side switching, while the parking lights may use Ground-Side switching. Before installing this product, it will be necessary to contact the vehicle manufacturer to determine which methods are used. After the proper methods have been established, follow the appropriate procedure, based on the method used by the headlight system.

If Your Headlights are Positive-Side Switched...

1. Mount the flasher in the engine compartment near the headlights.
2. **GROUND** - Connect the BLACK wire to the vehicle's chassis ground.
3. **NIGHT CUTOUT** - BROWN - Connect this wire to the parking light or low beam circuit to disable the flasher when headlights are on. This is to prevent both filament in a dual filament bulb from being on simultaneously (or if required in your jurisdiction).
4. **High Beam Override** - Splice the WHITE wire into the circuit the BLUE/WHITE wire is to be connected to in step 5. Splice the WHITE/BLACK wire into the circuit the ORANGE wire is to be connected to in step 7.
5. **Driver Side Lamp** - Locate the wire that connects the driver side high beam lamp to the headlight dimmer switch. Cut this wire at a point 3 inches away from the lamp. Connect the BLUE wire to the wire that connects to the high beam lamp. Connect the WHITE/BLUE wire to the wire that connects to the headlight dimmer switch.
6. **Passenger Side Lamp** - Locate the wire that connects the passenger side high beam lamp to the headlight dimmer switch. Cut this wire at a point 3 inches away from the lamp. Connect the YELLOW wire to the wire that connects to the high beam lamp. Connect the WHITE/YELLOW wire to the wire that connects to the headlight dimmer switch.
7. **On-Off Control** - Connect the ORANGE wire to a +12VDC power switch (200 mA MIN.(user supplied)).
8. **Lamp feed** - Connect the RED wire, fused at 15 Amps (customer supplied) to the POS (+) battery terminal.

If Your Headlights are Ground-Side Switched...

NOTE: Daytime Running Lights may control the +12VDC supplied to the headlights. Before proceeding, unplug each headlight and verify that while the vehicle is running, +12VDC is being provided. This flasher will not operate properly if +12VDC is not available.

1. Mount the flasher in the engine compartment near the headlights.
2. *GROUND* - Connect the BLACK wire to the vehicle's chassis ground.
3. *NIGHT CUTOFF* - BROWN - Connect this wire to the parking light or low beam circuit to disable the flasher when headlights are on. This is to prevent both filament in a dual filament bulb from being on simultaneously (or if required in your jurisdiction).
4. *High Beam Override* - Connect the WHITE wire to the vehicle's chassis.

Splice the WHITE/BLACK wire into the circuit the WHITE/BLUE wire is to be connected to in step 5.

5. *Driver Side Lamp* - Locate the wire that connects the driver side high beam lamp to the headlight dimmer switch. Cut this wire at a point 3 inches away from the lamp. Connect the BLUE wire to the wire that connects to the high beam lamp. Connect the WHITE/BLUE wire to the wire that connects to the headlight dimmer switch.
6. *Passenger Side Lamp* - Locate the wire that connects the passenger side high beam lamp to the headlight dimmer switch. Cut this wire at a point 3 inches away from the lamp. Connect the YELLOW wire to the wire that connects to

the high beam lamp. Connect the WHITE/YELLOW wire to the wire that connects to the headlight dimmer switch.

7. *On-Off Control* - Connect the ORANGE wire to a +12VDC power switch (200 mA MIN.(customer supplied)).
8. *Lamp Feed* - Connect the RED wire to the vehicle's chassis ground.

Flash Pattern Selection

There are 4 available flashrates for the UHF2150A. These rates are determined by two jumper wires;

WHITE/RED and WHITE/VIOLET. The following table defines the available flashrates.

WHT/RED	WHT/VIO	Flashrate
Intact	Intact	Moduflash
CUT	Intact	280 SF Alternating
Intact	CUT	140 DF Alternating/ 140 SF Simultaneous
CUT	CUT	140 DF Alternating/ 280 SF Alternating

SF = Single Flash per min.
DF = Double Flash Per Min.

Positive-side Switched Headlights

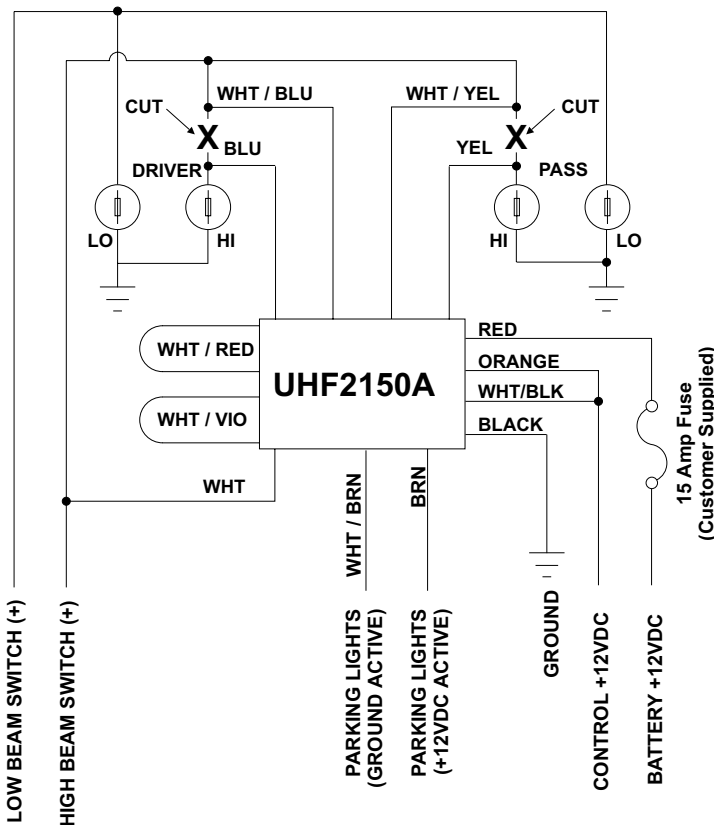

Negative-side Switched Headlights

