

CARSON

Carson Manufacturing Co., Inc.
5451 North Rural Street
Indianapolis, IN 46220
Phone: (888) 577-6877 Fax: (317) 254-2667
www.carsonsirens.com

SC-1002/1012-10 SIREN AMPLIFIER W/ LIGHT CONTROL

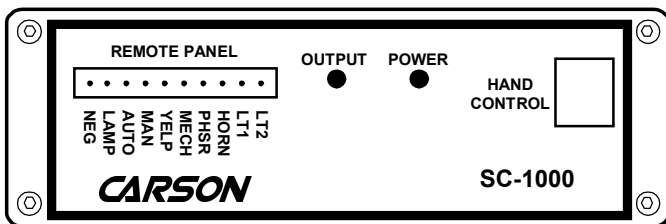
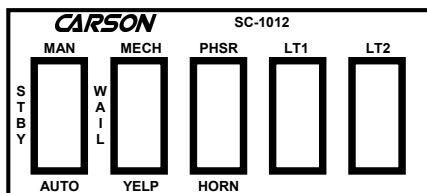
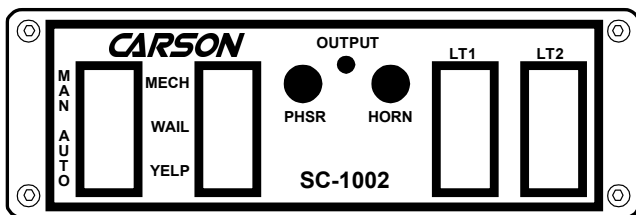

INSTALLATION AND OPERATING INSTRUCTIONS

Carson is a trademark of Carson Manufacturing Company, Inc.

WARNING Sound Hazard - Sound level from siren speaker (>120dBA @ 10 feet) may cause hearing damage. Do not operate siren without adequate hearing protection for you and anyone in immediate vicinity. (Ref. OSHA 1910.95 for occupational noise exposure guidelines)



TABLE OF CONTENTS

GENERAL DESCRIPTION 3
 SPECIFICATIONS 3
 INSTALLATION 4
 SAFETY PRECAUTIONS 4
 UNPACKING 4
 MOUNTING 4
 OPTION SWITCHES 5
 ELECTRICAL CONNECTIONS 5
 OPERATION 8
 POWER ON/OFF 8
 SIREN CONTROLS 8
 Man or Auto Selector Switch 8
 Mech - Wail - Yelp Selector Switch 8
 Phaser Button (SC-1002) or Rocker (SC-1012) 8
 Horn Button (SC-1002) or Rocker (SC-1012) 8
 Auxiliary Input Functions 8
 Horn Ring Cyclor 2 (HRC2) 8
 LIGHT CONTROLS 9
 Lighted Rocker Switches LT1 and LT2 9
 SERVICE 10
 PROBLEMS 10
 PARTS 10
 RETURNS 11
 WARRANTY 11

NOTICE

Due to continuous product improvements, we must reserve the right to change any specifications and information, contained in this manual at any time without notice.
 Carson Manufacturing Co., Inc. makes no warranty of any kind with regard to this manual, including, but not limited to, the implied warranties of merchantability and fitness for a particular purpose.
 Carson Manufacturing Co., Inc. shall not be liable for errors contained herein or for incidental or consequential damages in connection with the furnishing, performance, or use of this manual.

GENERAL DESCRIPTION

The SC-1002/1012 Siren Amplifier with Light Control is designed for single 100W speaker use. The primary operating modes are Mechanical, Wail, Yelp, and Standby, selected by 3-position rocker switches. Momentary Horn Override, Momentary Phaser Override or push-on/push-off Phaser operation while in the Mechanical, Wail, and Yelp modes. Manual siren control of Mechanical, Wail, and Yelp. Lights can be controlled with two rocker switches. The SC-1012 is a remote unit wired to a supplied switch panel or user supplied switches. An internal DIP switch provides options to change tones, disable tones, HRC2 operation, and Auxiliary input polarity. The unit utilizes short circuit, high voltage, and reverse polarity protection systems for maximum service life. An output light indicates siren signal output for troubleshooting.

SPECIFICATIONS

Siren Section						
Input Voltage	9 - 16 VDC (negative ground)					
Input Current	8 AMPS (@14 VDC - single 100W speaker)					
Standby Current	< 75 ma (@ 14 VDC w/ enable lead energized)					
Output Power	105 WATTS RMS MAX. (15 VDC - single 100W speaker)					
Siren Frequency	700Hz - 1500Hz (Mechanical 700Hz - 1600Hz; Two-Tone and Horn = 435 & 585Hz)					
Tones / Cycle Rates	Horn	Mechanical	Wail	Yelp	Phaser	Two-Tone
Cycle Rates	109 CPS	5 CPM	13 CPM	190 CPM	15 CPS	60 CPM
High Voltage Protection	16 - 18 VDC will cause siren output to cease, resume at normal voltage					
Short Circuit Current	50 AMPS (supply circuit must be capable of supplying this)					
Operating Temp.	-15° F to +140°F					
Controls	Two 3-position rocker switches (Mechanical, Wail, Yelp, Manual, and Standby). SC-1002 - Pushbutton switches (Horn and Phaser momentary or toggle). SC-1012 - Momentary rocker switch (Horn and Phaser momentary or toggle). Auxiliary input programmable for positive or negative activation. Internal 8-position DIP switch option selector.					
Connections	Screw down terminals for Positive and Negative Supply; Removable 6-Pos Terminal Block (2) Speaker, Auxiliary and Enable inputs, (2) light control outputs. SC-1012 has removable 10-Pos Terminal Block Plug for remote panel.					
Light Control Section						
Controls	Two lighted rocker switches.					
Current	20 AMPS per switch, 20 AMPS total					
Connections	Two light control outputs (see 6-Pos Terminal Block under Siren Connections)					
General						
Size	6" Wide, 6" Deep, 2" High					
Weight	SC-1002 - 3 LBS; SC-1012 - 3-1/2 LBS.					

INSTALLATION

Proper installation of the unit is essential for years of safe, reliable operation. Please read all instruction **before** installing the unit. Failure to follow these instructions can cause serious damage to the unit or vehicle and may void warranties.

SAFETY PRECAUTIONS

For the safety of the installer, vehicle operator, passengers and the community please observe the following safety precautions. **Failure to follow all safety precautions and instructions may result in property damage, injury or death.**

Qualifications - The installer must have a firm knowledge of basic electricity, vehicle electrical systems and emergency equipment.

WARNING **Sound Hazard** - Sound level from siren speaker (>120dBA @ 10 feet) may cause hearing damage. Do not operate siren without adequate hearing protection for you and anyone in immediate vicinity. (Ref. OSHA 1910.95 for occupational noise exposure guidelines)

Mounting - Mount the unit for easy access by the vehicle operator. DO NOT mount in air bag deployment area. Assure clearances before drilling in vehicle.

Wiring - Use wiring capable of handling the current required. Make sure all connections are tight. Route wiring to prevent wear, overheating and interference with air bag deployment. Install and check all wiring before connection to vehicle battery.

Testing - Test all siren functions after installation to assure proper operation. Test vehicle operation to assure no damage to vehicle.

Keep These Instructions - Keep these instructions in the vehicle or other safe place for future reference. Advise the vehicle operator of the location.

UNPACKING

Inspect contents for shipping damage. If found **alert carrier immediately**. Contents should include unit, mounting bracket, amplifier mounting hardware, 6-Pos connector, and these instructions. The **SC-1012** is also supplied with a remote panel containing switches, 10-Pos connector, and 3/16" quick-connect terminals. Contact supplier immediately if any components are missing.

MOUNTING

The mounting bracket supplied can be installed above or below the unit. Mounting bolts slide into channels on each side of the case. Lockwashers should be used between the case and bracket as well as between the bracket and nut. Choose a mounting location convenient to the operator and away from any air bag deployment areas. Inspect behind mounting area for clearance. Assure adequate ventilation to prevent overheating. Consider wire routing and access to connections. Install mounting bracket to vehicle using 1/4" hardware (not supplied).

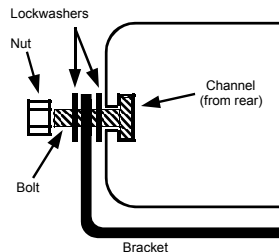

SC-1012: The remote panel of the SC-1012 is typically mounted underneath the vehicle dashboard using mounting hardware (not supplied). Mount the panel in a location away from the driver's or passenger's legs.

OPTION SWITCHES

An internal 8-position DIP switch on the circuit board may be changed to select various options.

Accessing Option Switches - the DIP switch is located just behind the front panel of the amplifier. Use a 7/64" allen wrench to remove the 4 corner screws and front panel.

SW-1 (AUX_P) Auxiliary Input Polarity - The auxiliary input is normally activated with positive. Turn switch off for negative activation.

SW-2 (INST_ON) Instant ON - The Enable input is normally required to turn on the unit. Turning this switch on allows the front panel switches to instantly turn on the unit. (SC-1002 and SC-1012 only)

SW-3 (T-T) Two-Tone - Two-Tone replaces Phaser tone by turning this switch on.

SW-4 (H_I) Horn Inhibit - Horn tone is disabled by turning this switch on. Horn will be replaced with Yelp.

Tone Disable - All siren tones may be disabled except Wail and Yelp by turning on "T-T" and "H_I" switches.

SW-5 (HRC) Horn Ring Cyclor 2 (HRC2) - While the siren is in standby, the auxiliary input can cycle through Mechanical, Wail, Yelp, and Phaser tones by repeatedly activating the auxiliary input. Turn this switch on for HRC2 feature. See OPERATION section for further details.

SW-6 (SM) Short Manual - The Manual siren tone will normally die out and stop when released. Turn this switch on to have Manual stop immediately.

SW-7 (MECH2) Mechanical Tone 2 - Turn this switch on for a different mechanical tone sound.

SW-8 (FALL) Mechanical Fall - Turn this switch on for a quicker mechanical tone fall time.

ELECTRICAL CONNECTIONS

Electrical connections to the unit are made using terminal block plug(s) and screw terminals located on the amplifier. Label(s) on the unit identifies each terminal function. Install the plug on the unit before wiring. If the unit needs service the plug can be easily removed without unwiring. The power supply of the unit must be capable of delivering peak currents up to 50 amps for adequate short circuit protection and reliable operation. The preferred source is directly at the vehicle battery. The amplifier is fused.

Attach leads by stripping 3/8", inserting into plug and clamp by tightening screw. Make sure the screw is tight and the wire can't be pulled out.

Failure to adequately tighten the screw can result in improper operation or burning the connector and wire.

Wire Size and Termination - The diagram shows the minimum wire size used for each connection, along with recommended lead color. If the wire is longer than 10 ft. use the next larger wire size. Use only high quality crimp connectors for installation on the vehicle.

Unit Enable Input Connection - This is like a power switch for the unit. Connect to a positive circuit controlled by the vehicle ignition switch, usually a terminal at the vehicle fuse panel. The required current is low (15mA typ.). Permanent power connection is not recommended as this keeps unit on unattended and may drain battery. The unit may also be configured without this connection. See **Instant ON** under OPTION SWITCHES section.

Auxiliary Input Connection - A momentary input typically connected to the horn ring of the vehicle. See **Auxiliary Polarity** under OPTION SWITCHES section for proper activation polarity. Input current is 1 to 20 mA.

ELECTRICAL CONNECTIONS (ALL MODELS)

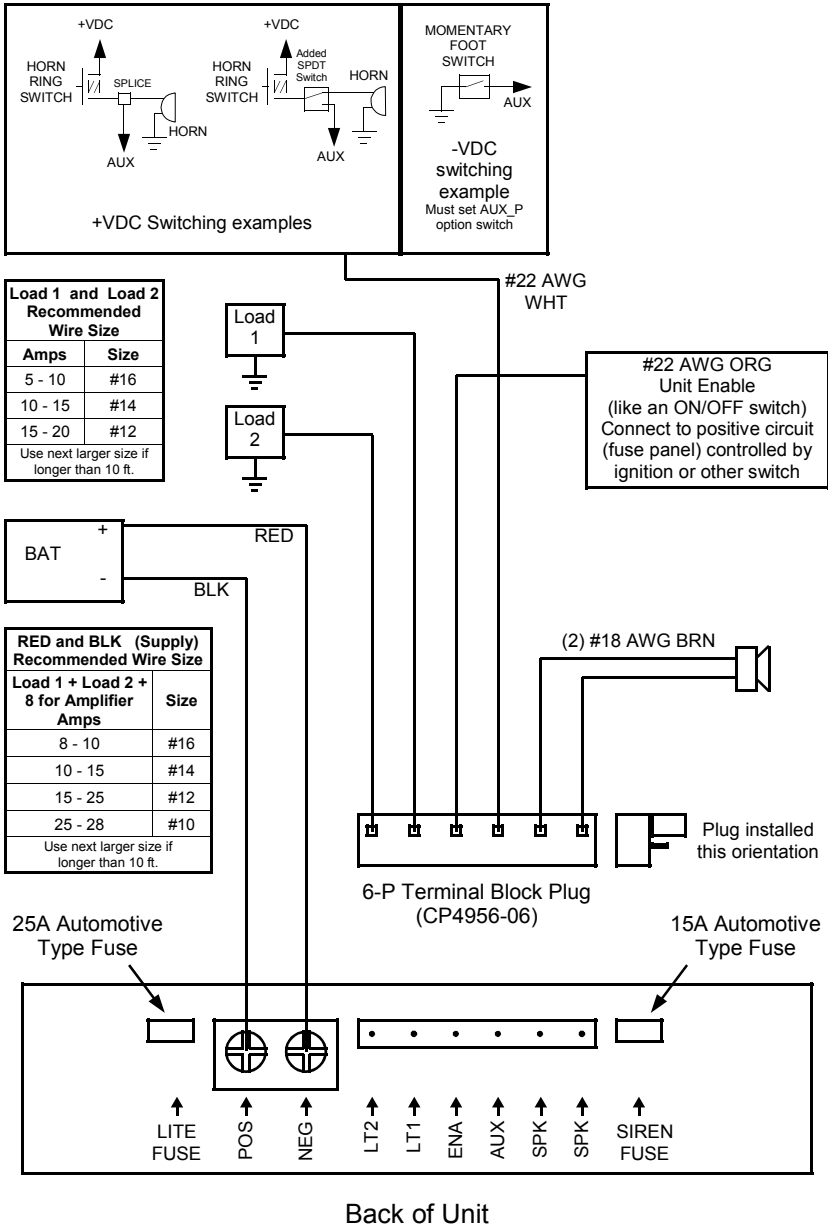

ELECTRICAL CONNECTIONS (SC-1012 only)

Front of Unit

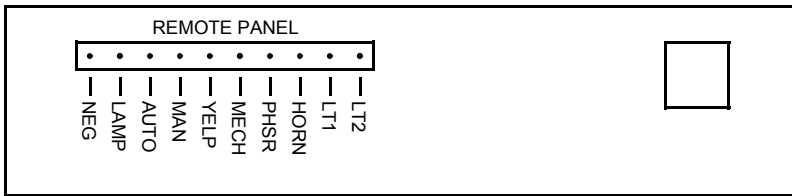

10-P Terminal Block Plug
(CP4688-10)



Plug installed
this orientation

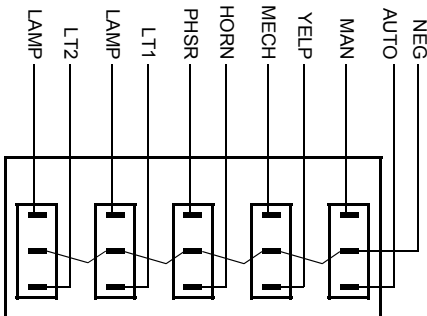

Note Top Orientation

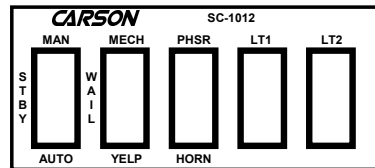

LT1 and LT2
Lighted Rocker Switch
Circuit

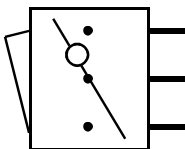

OPERATION

WARNING Sound Hazard - Sound level from siren speaker (>120dBA @ 10 feet) may cause hearing damage. Do not operate siren without adequate hearing protection for you and anyone in immediate vicinity. (Ref. OSHA 1910.95 for occupational noise exposure guidelines)



SC-1002 and SC-1012 Models

POWER ON/OFF

The unit is enabled (turned on) by applying positive voltage to the orange enable lead. On the SC-1002, backlight turns on. On the SC-1012 remote amplifier, **POWER** light comes on. This is normally controlled with the ignition switch on the vehicle. See INSTALLATION section. An **Instant ON** feature may be selected so the unit is turned on when the front panel controls are activated. See OPTION SWITCHES section.

SIREN CONTROLS

MAN or AUTO SELECTOR SWITCH

A 3-position rocker selector switch controls the primary operating mode of the siren.

Manual - Provides manual control of Mechanical and Wail tone rise and fall or momentary Yelp depending on the position of **Mech - Wail - Yelp** switch.

Auto - Keeps siren tone running (automatic rise and fall) depending on the position of **Mech - Wail - Yelp** switch.

Standby - A silent mode that may be overridden anytime.

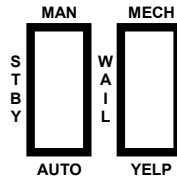

MECH - WAIL - YELP SELECTOR SWITCH

A 3-position rocker selector switch controls the primary siren tone.

Mech - A simulated mechanical siren tone. Tone may be changed or disabled. See OPTION SWITCHES section.

Wail - A slower changing tone used on highways.

Yelp - A rapidly changing tone used in congested areas.

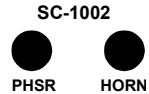

PHASER BUTTON (SC-1002) or ROCKER (SC-1012)

A very rapid changing tone used at intersections and very highly congested areas. With selector switch in **Auto**, this tone override is toggled on and off by repeatedly pressing switch. With selector switch in **Standby**, this tone override is momentary as long as the switch is pressed. May be optionally replaced with **Two-Tone** or disabled. Two-Tone is two alternating frequencies like a European. See OPTION SWITCHES section.

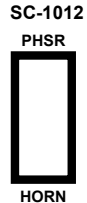

HORN BUTTON (SC-1002) or ROCKER (SC-1012)

Produces a simulated Air-Horn tone while pressed. Overrides all siren modes. Horn tone may be disabled. See OPTION SWITCHES section.

AUXILIARY INPUT FUNCTIONS

The switch or horn ring attached is intended to be momentary.

With selector switch in **Standby**, activating auxiliary is the same function as activating **Manual**.

Note that the orange enable lead must be activated for the unit to be on while in **Standby**.

When the selector switch is in **Auto** activating auxiliary is the same as pressing **Horn switch**.

Horn Ring Cyclor 2 (HRC2) - this feature may also be added by turning on the HRC2 option. HRC2 is only available while the unit is in **Standby**. Tapping the attached horn ring or other switch, will bring the unit out of standby into Mechanical tone. Repeatedly tapping the horn ring will cycle through Mechanical, Wail, Yelp, and Phaser tones. Tapping the horn ring twice quickly will stop the siren tones and return the unit to standby. Pressing and holding the horn ring will produce Horn tone until released. Then the siren will return to its previous siren tone or standby.

Selector Position	Mech - Wail - Yelp Position	Phaser Switch	Auxiliary Input (Horn Ring)
Standby	Silent	Momentary Phaser	Man. Mech., Wail, or Yelp or HRC2
Manual	Man. Mech., Wail, or Yelp	Phaser Toggle	Momentary Horn
Auto	Mechanical, Wail, or Yelp	Phaser Toggle	Momentary Horn

OPERATION (SC-1002 and SC-1012 Models continued)

LIGHT CONTROLS

LIGHTED ROCKER SWITCHES LT1 and LT2

When turned on the rocker switch will light up and activate the corresponding light output.

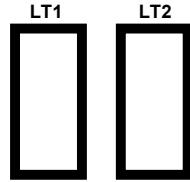

SERVICE

This unit is designed to provide years of reliable service under even the worst conditions. Many times there may appear to be a problem with the unit when the true problem is in the speaker, controlled devices, or improper installation. The following chart shows typical symptoms and possible causes.

A blown siren fuse doesn't necessarily mean that the unit is bad. If a speaker or speaker lead is shorted the fuse will blow before the unit is damaged. Disconnect the SPKR leads and replace the fuse. If the **OUTPUT** light comes on with siren power enabled and Wail mode selected it is OK. Check the speaker or leads for possible shorting.

PROBLEMS

Symptom	Possible Cause	Check
No power or siren output	No power to enable input Bad speaker Connector(s) loose Rear panel fuse blown Loose connection at power source	Does backlighting or POWER light (SC-1012) come on? Is the OUTPUT light on face coming on in Wail? Do you hear a "pop" when turned on? Is an external fuse or circuit breaker used? Are the negative leads connected to a good ground?
No siren tones	Bad Speaker High Voltage Protection	Is the OUTPUT light on face coming on in Wail? Input voltage must be less than highest rated voltage.
Distorted siren sound	Speaker assembly loose Intermittent Aux Input connection Low vehicle voltage	Is the speaker bell or tip loose? Is the Aux Input used and wired properly? Input voltage must be greater than lowest rated voltage.
Intermittent siren tone	High Voltage Protection Connector loose Bad power connection Circuit breaker in supply connection	Is the vehicle voltage regulator working properly? Is the connector tight on the back of the unit? Is there a loose connection on a power lead? Is a circuit breaker used with at least a 50A rating?
Horn function stuck on or Manual stuck on	Horn or Manual switch stuck Aux Input improperly connected Aux Input Polarity Option set wrong	Does the horn or manual switch return when released? Is the Aux Input used and wired properly? Is the AUX_P option properly configured?
Wrong siren tone	Two-Tone option installed Tones disabled.	Is the T-T option selected? Check option switch settings.
Some siren tones not working	Tone disabled	Check option switch settings.
Light switches not working	Loose output connections Rear panel fuse blown	Do the Light Control switch indicators light? Is the corresponding fuse blown?

PARTS

The following parts are available from Carson Manufacturing Company, Inc.:

Part	Description
CP4062-K2523	3/16" quick-connect terminal - AMP#2-520194-2 or equivalent (SC-1012 only)
ED1602	Hardware Kit (bolts, nuts, lockwashers)
CP3571	Bracket, mounting
CP4956-06	Connector, 6-pin Terminal Block Plug
CP4688-10	Connector, 10-pin Terminal Block Plug (SC-1012 only)
CP4990-150	Fuse, 15 Amp Mini Automotive (Siren)
CP4990-250	Fuse, 25 Amp Mini Automotive (Lite)
CP4748-2	Switch, Red Rocker ON - OFF - ON (Mech - Wail - Yelp)
CP4751-2	Switch, Momentary Red Rocker Switch, (ON) - OFF - (ON) (Phsr - Horn) (SC-1012 only)
CP4995-2	Switch, Red Rocker (ON) - OFF - ON (Man - Standby - Auto)
CP4993	Switch, Lighted Rocker for Light Control
CP4998	Transistor, output (replace in pairs, 2 required)
SC-1012-10CH	SC-1012 Remote Panel Assembly (includes rocker switches)
CP4997	Instruction Manual

RETURNS

If you have any questions concerning this or any other Carson product, please contact our **Technical Service Department** at (888) 577-6877. Many issues can be handled over the phone. We can also be reached via e-mail at service@carsonsirens.com

If a product must be returned for any reason, please contact our Technical Service Department to obtain a Returned Merchandise Authorization number (RMA#) before you ship the product to Carson. Please write the RMA# clearly on the package near the mailing label. Be sure to provide a return address, contact and phone number, along with a brief description of the problem.

LIMITED WARRANTY

Carson Manufacturing Company, Inc. warrants this new product to be free from defects in material and workmanship, under normal use and service, for a period of five (5) years from the date of delivery to the first user-purchaser.

During this warranty period the obligation of Carson Manufacturing is limited to repairing or replacing, as Carson Manufacturing may elect, any part or parts of such product which after examination by Carson Manufacturing is determined to be defective in material and/or workmanship.

This warranty does not cover labor charges for removal or re-installation of the product. Fuses and lamps are not covered under this warranty.

This warranty does not extend to any unit that has been subjected to abuse, misuse, improper installation or which has not been adequately maintained, nor to units which have problems related to service or modification at any facility other than Carson Mfg.

THERE ARE NO OTHER WARRANTIES, EXPRESSED OR IMPLIED, INCLUDING BUT NOT LIMITED TO, ANY IMPLIED WARRANTIES OF MERCHANTABILITY OR FITNESS FOR A PARTICULAR PURPOSE. IN NO EVENT SHALL CARSON MANUFACTURING COMPANY, INC. BE LIABLE FOR ANY LOSS OF PROFITS OR ANY INDIRECT OR CONSEQUENTIAL DAMAGES ARISING OUT OF ANY SUCH DEFECT IN MATERIALS OR WORKMANSHIP.

BLANK PAGE