

FLASH-1, FLASH-2, FLASH-3 SOLID STATE HEADLIGHT FLASHER

NEW! NOW ALL FLASH-x HAVE AN AMP CONNECTOR.

ITEMS INCLUDED

- ① FLASH-(1, 2, 3) Solid State headlight flasher.
- ① Instruction Sheet.
- ① Wiring Harness

TECHNICAL SPECIFICATIONS

VOLTAGE RATING.....	12 Volts dc.
AMPERAGE RATING.....	13 Amps.
FLASHING PATTERN.....	FLASH-1: 1.9 Flashes Per Sec.
 FLASH-2: 1.9 Triple Flashes Per Sec.
 FLASH-3: 3.0 Flashes Per Sec.
DUTY CYCLE:	50% duty cycle.
WARRANTY:	2 Years Factory Direct.

PHYSICAL DIMENSIONS

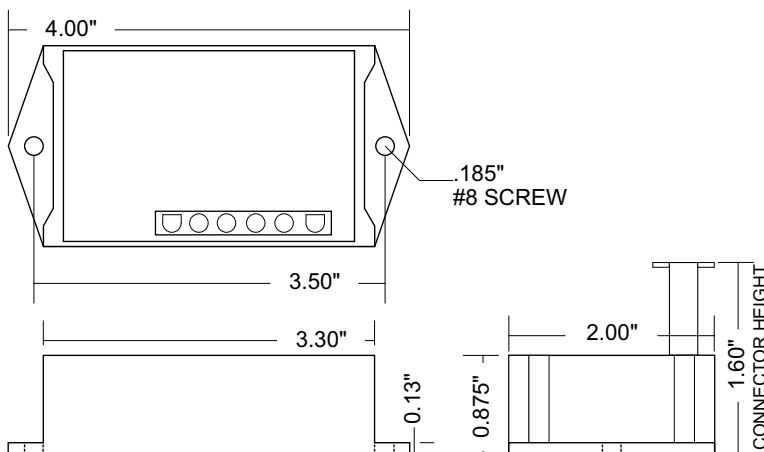

WIRING HARNESS

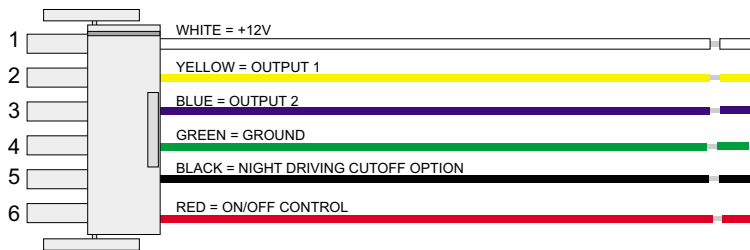

INSTALLATION

NOTE: Please contact Nova before installing on a foreign made (non-Chrysler, Ford, or General Motors) vehicle. This flasher was not designed to be used on vehicles with DAYTIME RUNNING LIGHTS.

- 1. Mounting:**
Mount the FLASH-x in the engine compartment as close to the battery and headlight wiring as possible.
- 2. Electrical wiring:**
Connect the supplied six wire harness as follows: (Note: Use 16AWG or greater unless otherwise specified.)

WIRING DIAGRAMS ARE ON REVERSE SIDE...

INSTALLATION

WHITE: Connect through a fuse to Battery positive(+). Use a 20 Amp fuse on a vehicle with two headlights. Use a 30 Amp fuse on a vehicle with four headlights. Do not use a fusible link or circuit breaker.

! DO NOT CONNECT WHITE WIRE TO A SWITCH !
Do not connect WHITE + RED to the same ON/OFF switch! This wire must be connected to +12V at all times. If the white wire is not connected to +12V when the HIGH-BEAMS are activated it may damage the flasher.

GREEN: Connect to Chassis GND or Battery negative(-).

Find the wire which connects the DRIVER SIDE high-beam to the PASSENGER SIDE high-beam. Cut this wire about one foot from the back of the headlight.

BLUE: Wire to the high-beam which is fed by the HIGH-BEAM WIRE. (Typically the DRIVER SIDE)

YELLOW: Wire to the high-beam which is at the end of the high-beam circuit (Typically the PASSENGER SIDE) (Note: Some vehicles have the HIGH BEAM FEED on the Passenger Side of the vehicle. If this is the case, only one high beam will function. Swap the BLUE and YELLOW wires to correct.)

RED: Connect to the flasher on/off switch. The other terminal of the switch must be connected to +12V. (Note: This is a *low current* connection and can be run with as low as 22AWG wire)

BLACK: • *OPTIONAL* • Automatic shutoff for Night Driving.

Splice into the wire powering the PARKING LIGHTS. *Do not connect to the low-beam circuit.* If not used, cut off the wire or wrap end with electrical tape.

USING THE FLASH-x

Normal headlight functions are not affected by the installation of the FLASH-x flasher. Activating the FLASH-x will alternate the high-beams only. The low-beams operate normally. The headlight dimmer switch overrides the FLASH-x. When the dimmer switch is pressed, the FLASH-x is de-activated and both high-beams function as normal. Pressing the dimmer switch again re-activates the FLASH-x.

If Automatic Shutoff for Night Driving is used (Black wire), the FLASH-x is disabled whenever the parking lights or headlights are on.

Safety Note: Disconnect the FLASH-x before doing any welding on the vehicle chassis as this may cause damage to the unit.

WIRING DIAGRAMS

FOR A VEHICLE WITH A 2 HEADLIGHT SYSTEM:

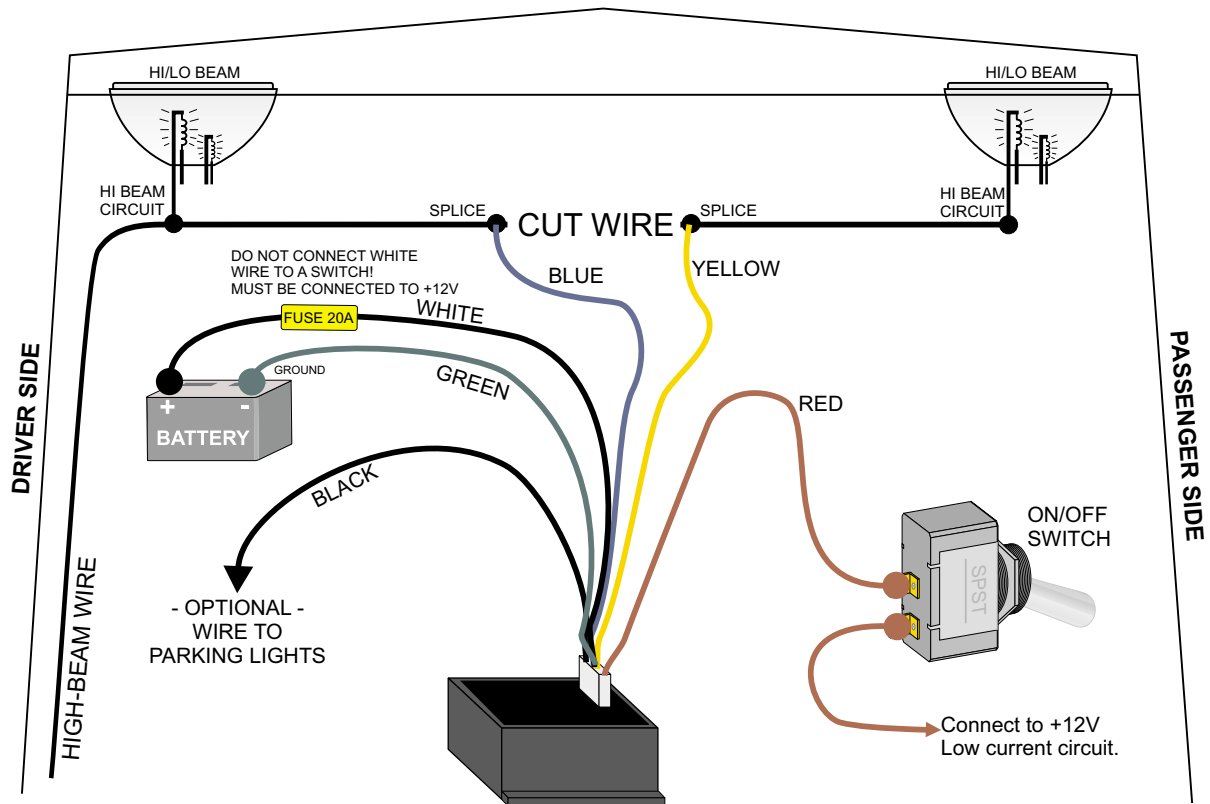

FOR A VEHICLE WITH A 4 HEADLIGHT SYSTEM:

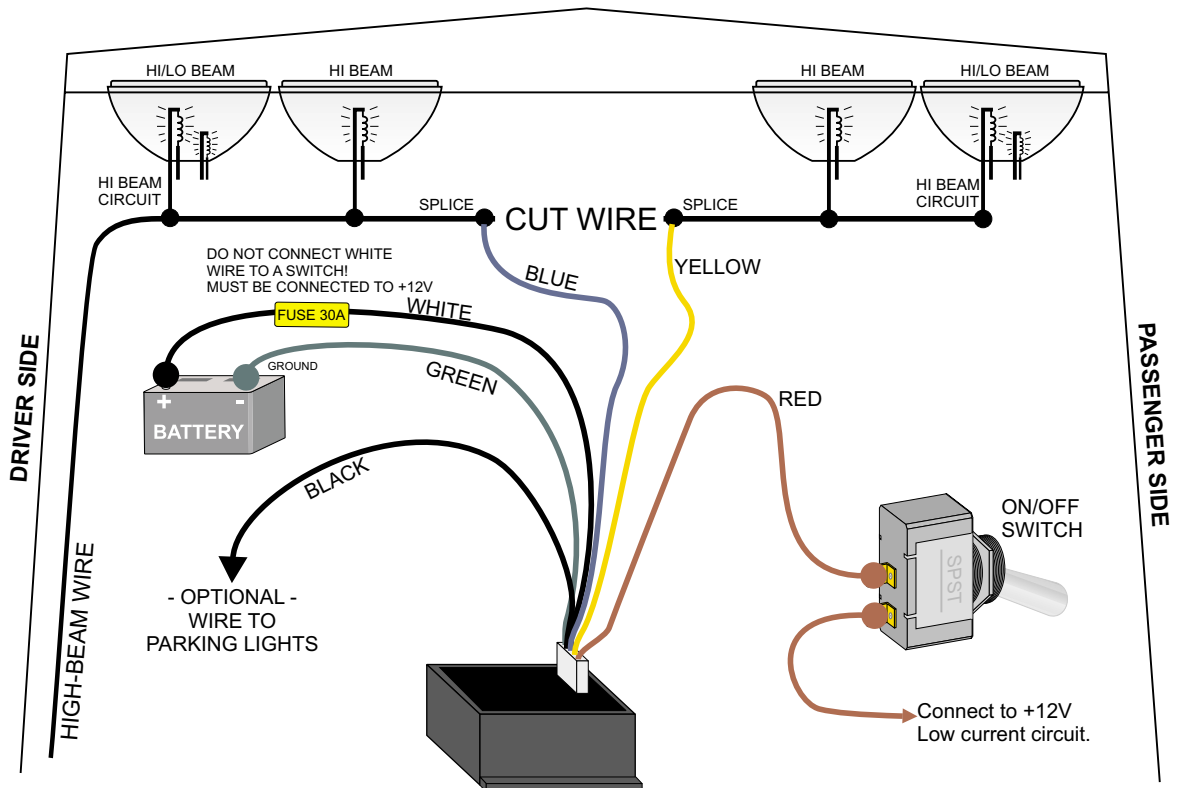

NOTE: HIGH BEAMS ARE TYPICALLY 'FED' FROM THE DRIVER SIDE WIRE. SOME LATE MODEL VEHICLES HAVE THE HIGH BEAMS FED FROM THE PASSENGER SIDE. SWAP THE BLUE AND YELLOW WIRES IF FED FROM THE PASSENGER SIDE.