

INSTRUCTION SHEET FOR HIGHLIGHTER™ LED LIGHT ASSEMBLIES

SAFETY MESSAGE TO INSTALLERS AND USERS



People's lives depend on your safe installation of our products. It is important to read, understand and follow all instructions shipped with this product and the related add-on products. In addition, listed below are some other important safety instructions and precautions you should follow:

- To properly install this light: you must have a good understanding of automotive electrical procedures and systems, along with proficiency in the installation and use of safety warning equipment.
- When drilling into a vehicle structure, be sure that both sides of the surface are clear of anything that could be damaged. Remove all burrs from drilled holes. To prevent electrical shorts, use grommets at all drilled holes through which wiring passes.
- A light system is a high current device. In order for it to function properly, a separate ground connection must be made. If practical, it should be connected to the negative battery terminal. At a minimum, it may be attached to a solid metal body or chassis part that will provide an effective ground path as long as the light is to be used.
- Because vehicle roof construction and driving conditions vary, Federal Signal does not recommend driving a vehicle with a magnetically mounted warning light installed. The light could fly off the vehicle causing injury or damage. Repair of damage incurred because of ignoring this warning shall be the sole responsibility of the user.
- Locate light system controls so the VEHICLE and CONTROLS can be operated safely under all driving conditions.
- You should frequently inspect the light to ensure that it is operating properly and that it is securely attached to the vehicle.
- File these instructions in a safe place and refer to them when maintaining and/or reinstalling the product.

Failure to follow all safety precautions and instructions may result in property damage, serious injury, or death to you or others.

I. GENERAL.

This instruction sheet provides directions for installation, wiring, and maintenance of the LED Highlighter Mini-Lightbar Light Assemblies.

The LED Highlighter is a high performance warning light with a small outline and low current draw. Advanced functionality enables the LED Highlighter to control or be controlled as part of a greater lighting system. It has two alternating high side flasher outputs, with a 7.5 amp capacity each. This allows a perimeter lighting system to be sequenced with the flash pattern of the Highlighter. A synchronize feature also enables two or more LED Highlighters to flash in unison. An external low side flasher, such as 650202, 650203 or 650206 may also be used to control the light using the "sync in" tab.

The active flash pattern may be selected from the 19 available.

After unpacking the Light Assembly, inspect it for damage that may have occurred in transit. If the unit has been damaged, do not attempt to install or operate it. File a claim immediately with the carrier, stating the extent of damage. Carefully check all envelopes, shipping labels, and tags before removing or destroying them. Ensure that the parts listed in the KIT CONTENTS LIST are contained in the packing carton.



To avoid damage when drilling, ensure that both sides of mounting surface are clear of any parts or wires. Also, when drilling any holes, ensure that holes are drilled only through sheet metal and not through upholstery. For some applications, temporary removal of interior trim may be needed. Consult vehicle manufacturer for proper procedures.

Specifications:

Length		15.3"
Width		8.4"
Height	Permanent mount	2.66"
	Mag. mount	3.03"
	Suction cup mount	3.00
Weight	Permanent mount	3.4 lb
	Mag mount	4.5 lb
	Suction cup mount	6.0 lb
Current draw		
Highlighter only		5 amps maximum
	Highlighter with high side outputs used	12.5 amps maximum
Fuse ratings		
	Highlighter fuse	7.5 amps (internal)
	High side output	7.5 amps (internal)
	Main power connection	Recommended 15 amps (installer supplied)

II. KIT CONTENTS LIST.

NOTE

These parts are not included with the magnetic or magnetic suction cup mount models.

Qty.	Description	Part Number
4	Screw, Thd. Form., 1/4"	7011A158A-12
1	Grommet	8108A002
1	Foam Mounting Pad	8560102

III. INSTALLATION.



When installing equipment inside air bag equipped vehicles, the installer MUST ensure that the equipment is installed ONLY in areas recommended by the vehicle manufacturer. Failure to observe this warning will reduce the effectiveness of the air bag, damage the air bag, or potentially damage or dislodge the equipment, causing serious injury or death to you or others.

The Light Assembly is completely wired at the factory and does not require any additional internal wiring. User-supplied 18 gauge or larger wire may be added if required. Optional 15-foot cable kits are available from your dealer.

Before beginning any installation process, plan the wiring path and mounting method. Depending on the number of units installed and the distance between connection points heavier gauge wire may be needed for connection.

A. Initial Permanent Mount Installation Steps.

1. Select a relatively flat and level position on the mounting surface. See figure 1. There are two sets of mounting holes. Pattern A matches the pattern found on the Halogen and Strobe Highlighter models. Pattern B is an alternate set of holes, closer to the corners for greater stability. Select the pattern most appropriate for your installation and scribe four drill position marks on the mounting surface. The wire routing hole can be located beneath the wire exit. If the wires will be routed down,

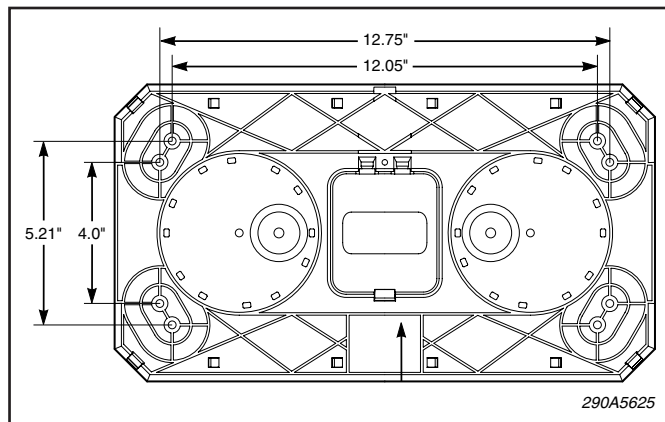

Figure 1.

scribe a drill position mark for wire routing hole on the mounting surface at the desired location. A channel is provided to run the wires to the back of the unit, if that suits the installation.

2. Drill four 9/32" holes (mounting holes) at the previously scribed drill position marks. If the installation requires it, drill one 1/2" hole (wire routing hole) at the previously scribed drill position mark. Install the grommet in the wire routing hole.

NOTE

If the wire will need to be routed through the mounting pad, carefully cut an opening in the pad and route the light assembly wires through it.

NOTE

There are Highlighter LED models where LED's are omitted along the rear face of the light. This is done to prevent light flashing in a direction that light is not desired. A label is placed on the domes of these lights stating "NO LIGHT OUTPUT - THIS SIDE". Attention should be given to these models to ensure the light is mounted in the correct direction.

B. Wiring.

1. The permanent mount LED Highlighter is provided with 18" of lead wire or 15 feet of cable, pre-installed. This may have to be spliced into the harness using installer supplied terminals. There is the option of running an intact wire into the unit to avoid leaving a splice exposed. See figure 2. Remove the screw securing the wire entry cover with a 1/4" driver. Use a flat tip screwdriver to release the lock tab. See figure 3. Remove the 18" red and black wires. The harness wiring will need to be terminated using installer provided terminals. Crimp 1/4" Fast-on receptacles to the positive wire and ground wires.

2. At this time, other additional features of the LED Highlighter may be connected. If the 18" wires and any extra features are to be used, this cover will have to be removed. .187" Fast-On receptacles will fit the option tabs.

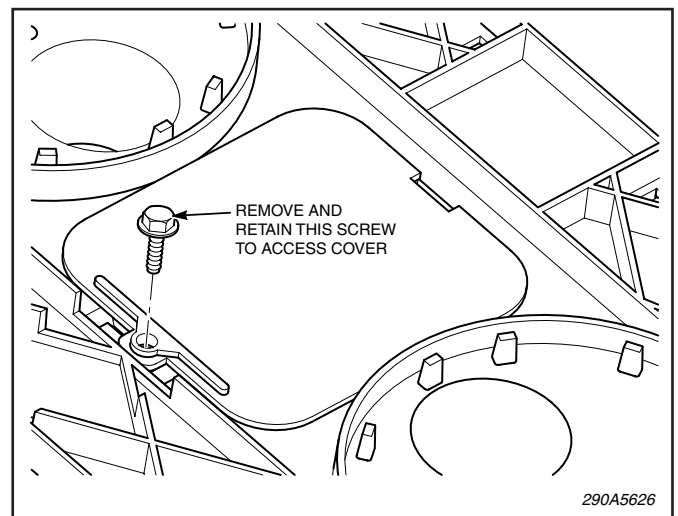

Figure 2.

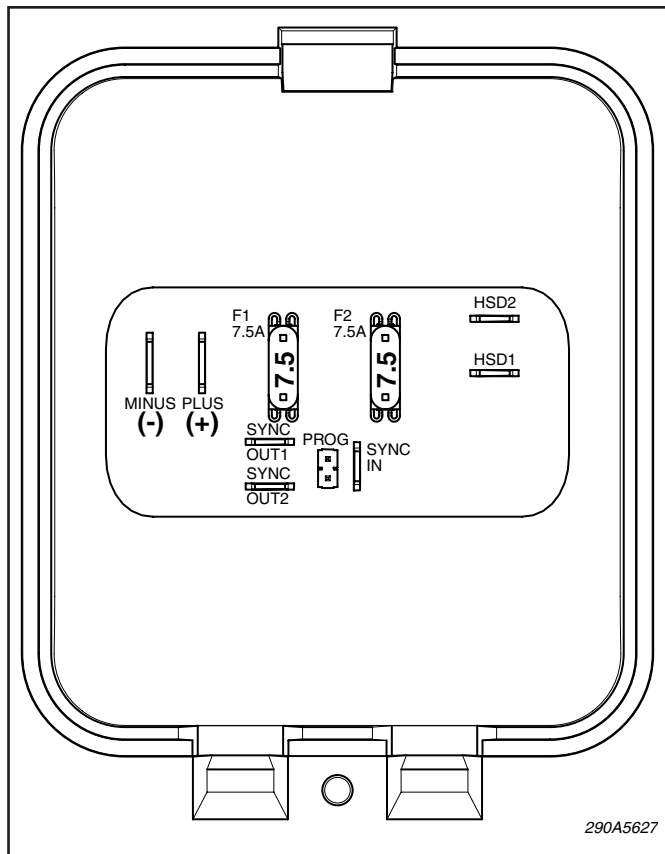

Figure 3.

3. Sync Feature.

The synchronize feature of the LED Highlighter allows two or more units to flash together or alternately. There are two terminals marked “sync out 1” or “sync out 2”. Each output is tied to a particular set of LEDs in the main unit and will provide a signal to other LED Highlighters to turn on. Sync 1 and sync 2 will flash alternately. There are patterns where the main unit will have different sets of LEDs lit. It should be noted that the Led Highlighters driven by their “sync in” tab will light up completely. Selection of a pattern where the entire bar is lit when flashing will result in the best appearance for a synchronized system.

Select a LED Highlighter to be the controlling unit. Using .187" Fast-Ons, connect an 18 Awg wire(s) to the sync out 1 or 2 terminal(s). Route this wire to the location of any other LED Highlighter that is to be flashed synchronously. Connect this sync wire to the “sync out” tab on the unit selected to be the controller and to the “sync in” terminal on any unit to be controlled. Both sync channels may be connected to separate banks of Highlighters to create sophisticated flash patterns. The Highlighters selected to be controlled, must be set into pattern #21 for the “Sync In” tab to be active.

NOTE

The “sync in” may also be connected to a low side flasher such as models 650202, 650203 or 650206. Connecting this terminal to ground will illuminate the entire light. Several Highlighters may be connected to the same flasher channel. The power and ground connections at the Highlighter are still required.

NOTE

The Highlighter LED should be set to pattern #21 for the “sync in” tab to become active.

4. High Side Outputs.

Two high side flasher outputs are also provided. These may be connected to external loads rated up to 7.5 amps each, which are to flash in sequence with the Highlighter. Connect a properly sized wire to the .187" tab marked “HSD1” or “HSD2”, and to the positive terminal on each load. HSD1 will provide +12VDC when the Sync1 is active. HSD2 will provide +12VDC when Sync 2 is active. These outputs are protected by a single, 7.5 amp mini fuse. When these high side outputs are used, add their total current to that of the LED Highlighter when selecting the size of the wiring used for installation.

C. Final Permanent Mount Installation Steps.

1. If the grommet is to be used, route the wires through it. Apply silicone sealing compound around the wires and grommet where the wires pass through the mounting surface to prevent leakage if they enter a weather tight compartment. Otherwise, route the wires through the wire channel provided in the base, to the back of the light.

2. Install a user-supplied control head or switch at a location which allows the vehicle and all controls to be operated safely under all driving conditions. Switch current capacity should be at least 15 amps. The positive 12VDC connection should be made to the fuse block if it is only to be operational when the vehicle is keyed on. Ensure that this connection is protected by a 15 amp fuse. Although the Highlighter LED has internal fuses for protection, it is recommended to protect the wiring with a fuse as well. The fuse should be located on the positive wire, as close to the power source as possible. Insulate any exposed connections with electrical tape or heat shrink tubing.

CAUTION

Light Assembly will not function properly without a good ground connection. Ensure that the black wire is attached to known good vehicle ground.

3. Route user-supplied wires, or the optional cable kit, from the control head or switch to the light assembly wires.

Connect the black ground wire to ground. Extend the wire as needed to reach a reliable ground connection.

CAUTION

To prevent a short circuit or broken wire, dress the wires to avoid pinching between the base plate and mounting surface. Also, do not allow the mounting screws to pierce the wires.

4. If the pins are to be used for selecting the flash pattern, test the light now for proper operation

and select the pattern by any of the methods described in section IV. Set any LED Highlighters that are to be remotely controlled by the main unit to the pattern #21. See table 1 for a description of the available patterns.

5. Re-attach the wire entry cover. The cover has two separate locations for wires to exit the cavity. Each opening can accommodate three 16-18 ga. wires. Guide the wires through the two openings. Secure with the screw removed previously.

NOTE

The screws provided are 5/8" long, this will provide 1/4" of thread engagement when using the mounting pad and a 1/8" thick mounting surface. If the mounting surface is thicker, longer screws are needed, or the optional pad may be omitted, provided that there is a minimum of 1/4" of full thread engagement into the base.

6. Carefully position the light assembly over the mounting holes with the mounting pad in place (if it is to be used) between the light and the mounting surface. Ensure that the wiring is routed neatly. Secure the light assembly to the mounting surface using the 1/4" thread-forming screws.

D. *Magnetic, or Magnetic / Suction Cup Mount.*



Because vehicle roof construction and driving conditions vary, Federal Signal does not recommend driving a vehicle with a magnetically mounted warning light installed. The light could fly off of the vehicle causing injury or damage. Repair of damage incurred because of ignoring this warning shall be the sole responsibility of the user.

SAFETY MESSAGE TO OPERATORS



Holding power of magnetic mounting systems is dependent upon surface finish, surface flatness, and thickness of the steel mounting surface. Therefore, to promote proper magnetic mounting:

- **Mounting surface and magnets must be kept clean, dry, and free of foreign particles that prevent good surface contact.**
- **Ensure that the mounting surface is flat.**
- **Magnetic mounting system should not be used on vehicles with vinyl tops.**

1. Place the light assembly on the vehicle roof at a location, which provides maximum signaling effectiveness for your application.

Table 1.

1.	Alternating Quad Flash
2.	Full Quad Flash – 80 Quad Flashes per Minute
3.	Continuous Flash – 75ms On 75ms Off
4.	Alternate Double Flash – 75 Double Flashes per minute – Sides Alternate with Front and Back
5.	Rotate With 2 Heads On – 75ms Between Flashes
6.	Rotate With 2 Heads On – 50ms Between Flashes
7.	Alternate Triple Flash – 90 Alternating Triple Flashes per minute.
8.	Alternating Sides Quad Flash – 60 Alternating Quad Flashes per minute.
9.	Continuous Flash – 125ms On 125ms Off – 240 FPM
10.	NFPA Flash – 400ms On 400ms Off – 75 FPM
11.	Continuous Flash – 250ms On 250ms Off – 120 FPM
12.	Rotate Left Followed by Full Quad – 67 Full FPM
13.	Double Flash Followed by Alternating Side Quad Flash – 40 FPM
14.	Rotate Heads Inside Out – 340 FPM
15.	Rotate Heads Inside Out and Back In – 120 FPM
16.	Scroll Heads From End to End – 75 FPM
17.	Rotate Heads Once Followed by Scroll Left to Right – 85 FPM
18.	Fedpulse 150 – 150 Pulsed Flashes
19.	Fedpulse 75 – 75 Pulsed Flashes
20.	Steady – Test Marking Pattern
21.	Sync Input – Entire Bar and Auxiliary Outputs Turn On When Sync In Line is Pulled Low.

2. For models with suction cups, release trapped air by applying downward pressure to the top of the dome while pulling up on the release tabs.

3. To operate the magnet mount light assembly, insert the plug at the end of the cable assembly in the cigarette lighter socket. Turn the unit on and off using the power switch on the plug. A pilot light will illuminate, indicating power is on.

4. To remove models with suction cups; pull up on the release tabs while picking up the lightbar.

IV. CONFIGURATION.

The active flash pattern may be selected in one of two ways.

A. *Jumper Pins.*

Two pins are located in the wiring compartment, the cover will have to be removed, see installation step III.B.1. While power is applied to the power and ground terminals, jumper the two pins with a conductive object such as a small screwdriver or paperclip. Each time the pins are shorted the pattern will change to the next in the sequence. When the desired pattern is reached, allow the unit to operate for 10 seconds before removing power. The pattern will be set in memory. Re-attach the cover.

B. *Program Selection using a Magnet.*

NOTE

A sufficiently strong magnet will be needed to change patterns. A typical retrieval tool should have enough strength. A refrigerator magnet will most likely not have the required strength.

Locate the programming sensor zone (hall effect switch) as shown in figure 4. The internal circuit board will

have a hole. Obtain a small, strong magnet, and hold it over the hole, within 1/8th of an inch. The pattern will move to the next in the sequence. Allow the light to flash for at least one entire flash sequence. Repeat this movement to progress to the next pattern. It will not progress another pattern until the magnet has been removed and re applied after an entire pattern sequence. When the desired pattern is reached, allow the unit to operate for 10 seconds before removing power. The pattern will be set in memory.

V. MAINTENANCE.

A. *Cleaning the Plastic Dome.*



Crazing (cracking) of dome will cause reduced effectiveness of light system. Do not use cleaning agents (which will cause crazing) such as strong detergents, solvents, or petroleum products. If crazing of dome does occur, reliability of light for emergency warning purposes may be reduced until dome is replaced.

Ordinary cleaning of the plastic dome can be accomplished by using mild soap and a soft rag. Should fine scratches or a haze appear on dome, they can ordinarily

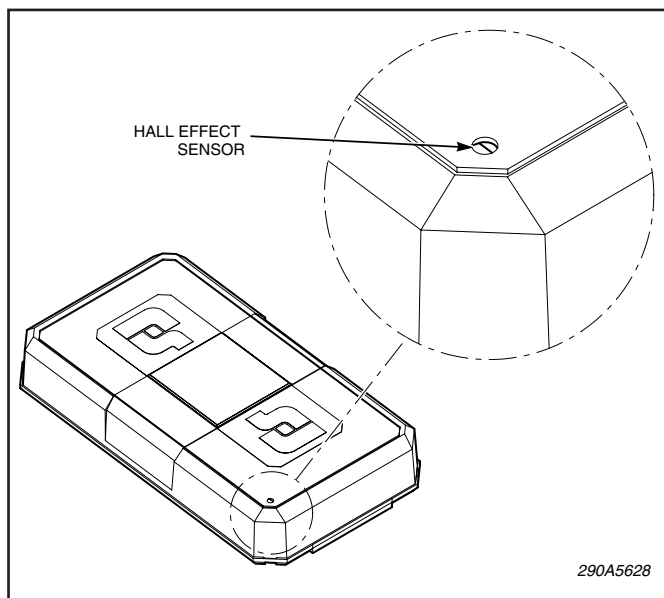

Figure 4.

be removed with a non-abrasive, high quality, one-step, automotive paste cleaner/wax and a soft cloth. The most effective product you can use for cleaning, protecting, and polishing clear and colored plastics is Plexus. Plexus is available through Federal Signal Corporation, Emergency Products in either 7-ounce cans (PX7) or 13-ounce cans (PX13).

Over time, exposure to heat, sunlight, smog, etc. will cause plastic to fade, discolor, scratch, or become brittle. Plexus seals the pores of the plastic making the domes easier to clean, improving scratch resistance, and increased product longevity.

B. *Service.*

The Federal factory will service your equipment or provide technical assistance with any problems that cannot be handled locally.

Any units returned to Federal Signal for service, inspection, or repair must be accompanied by Return Material Authorization. This R.M.A. can be obtained from a local Distributor or Manufacturer's Representative.

At this time a brief explanation of the service requested, or the nature of the malfunction, should be provided.

Address all communications and shipments to:

Federal Signal Corporation
Emergency Products Division
Service Department
2645 Federal Signal Drive.
University Park, IL 60466-3195
800-433-9132

Copyright 2006 Federal Signal Corporation