

WHELEN[®]

ENGINEERING COMPANY INC.

Route 145, Winthrop Road,
Chester, Connecticut 06412

Phone: (860) 526-9504

Fax: (860) 526-4078

Internet: www.whelen.com

Sales e-mail: autosale@whelen.com

Canadian Sales e-mail: autocan@whelen.com

Customer Service e-mail: custserv@whelen.com

Wiring Guide: ALPHA Switches 1-4

Automotive: Sirens/Switches

Safety First

This document provides all the necessary information to allow your Whelen product to be properly and safely installed. Before beginning the installation and/or operation of your new product, the installation technician and operator must read this manual completely. Important information is contained herein that could prevent serious injury or damage.

- **Proper installation of this product requires the installer to have a good understanding of automotive electronics, systems and procedures.**
- **If mounting this product requires drilling holes, the installer MUST be sure that no vehicle components or other vital parts could be damaged by the drilling process. Check both sides of the mounting surface before drilling begins. Also de-burr any holes and remove any metal shards or remnants. Install grommets into all wire passage holes.**
- **If this manual states that this product may be mounted with suction cups, magnets, tape or Velcro™, clean the mounting surface with a 50/50 mix of isopropyl alcohol and water and dry thoroughly.**
- **Do not install this product or route any wires in the deployment area of your air bag. Equipment mounted or located in the air bag deployment area will damage or reduce the effectiveness of the air bag, or become a projectile that could cause serious personal injury or death. Refer to your vehicle owners manual for the air bag deployment area. The User/Installer assumes full responsibility to determine proper mounting location, based on providing ultimate safety to all passengers inside the vehicle.**
- **For this product to operate at optimum efficiency, a good electrical connection to chassis ground must be made. The recommended procedure requires the product ground wire to be connected directly to the NEGATIVE (-) battery post.**
- **If this product uses a remote device to activate or control this product, make sure that this control is located in an area that allows both the vehicle and the control to be operated safely in any driving condition.**
- **Do not attempt to activate or control this device in a hazardous driving situation.**
- **It is recommended that these instructions be stored in a safe place and referred to when performing maintenance and/or reinstallation of this product.**
- **FAILURE TO FOLLOW THESE SAFETY PRECAUTIONS AND INSTRUCTIONS COULD RESULT IN DAMAGE TO THE PRODUCT OR VEHICLE AND/OR SERIOUS INJURY TO YOU AND YOUR PASSENGERS!**

For warranty information regarding this product, visit www.whelen.com/warranty

WARNING!

DISCONNECTING THE VEHICLE BRAKE LAMP CIRCUIT USING ANY SIRENS WITH RELAY OUTPUTS OR SWITCH CONTROLLERS COULD CAUSE VEHICLE OR PROPERTY DAMAGE, SERIOUS INJURY OR EVEN DEATH.

DISABLING THIS CIRCUIT IS A VIOLATION OF THE FEDERAL MOTOR VEHICLE SAFETY STANDARD FOR THE THIRD BRAKE LIGHT, AS WELL AS REAR BRAKE LIGHTS.

FUNCTIONS THAT BLACK OUT THE REAR BRAKE LIGHTS (SOMETIMES CALLED “BRAKE LIGHT CUT OUT”) MAY INTERFERE WITH THE BRAKE SHIFT LOCK MECHANISM, AND CAUSE THE VEHICLE TO MOVE UNEXPECTEDLY AND DANGEROUSLY.

DISCONNECTING THE BRAKE LIGHTS IN ANY WAY IS AT YOUR OWN RISK AND IS NOT RECOMMENDED BY WHELEN.

OPTION TABLE -SWITCH ASSEMBLY (Alpha 1)

Connecting the GREEN wire to the wire(s) below will enable the following specific siren tones:

WHITE/BROWN = WAIL WHITE/ORANGE = Hands Free
 WHITE/RED = YELP WHITE/BROWN + WHITE/RED = PIERCER

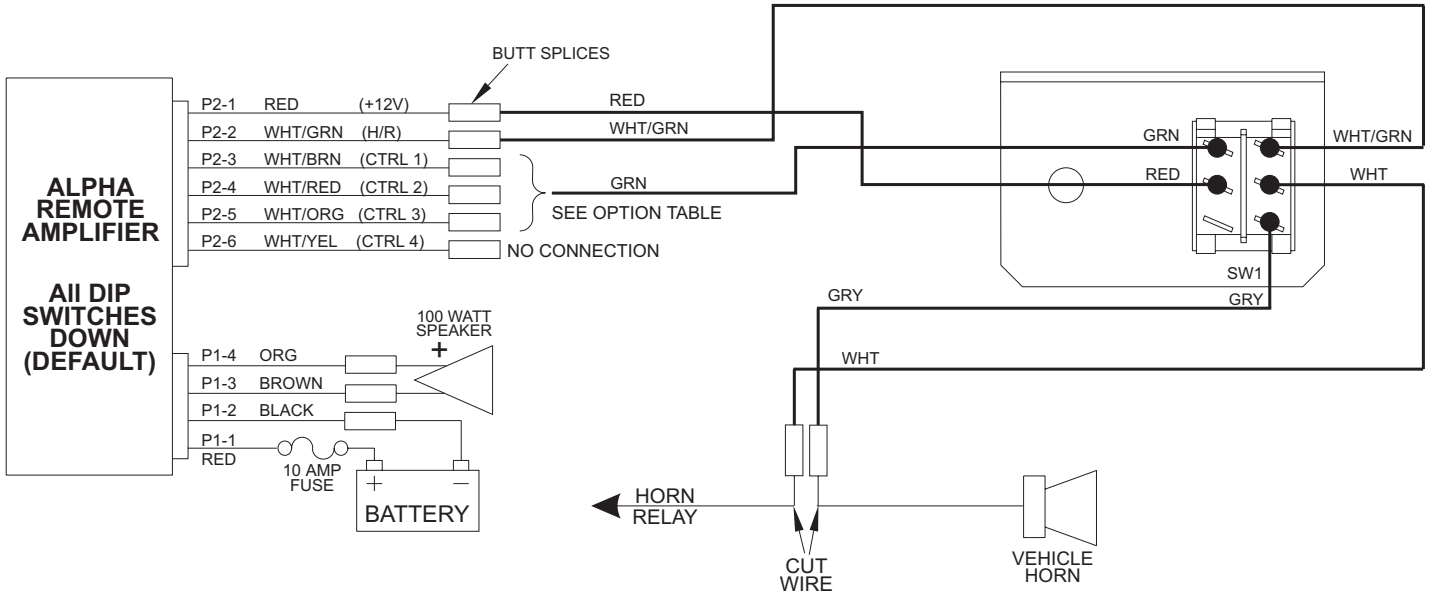

OPTION TABLE-SWITCH ASSEMBLY (Alpha 2)

Connecting the GREEN wire to the wire(s) below will enable the following specific siren tones:

WHITE/BROWN = WAIL WHITE/ORANGE = Hands Free
 WHITE/RED = YELP WHITE/BROWN + WHITE/RED = PIERCER

A simulated Air Horn tone is always available by pressing SW2.

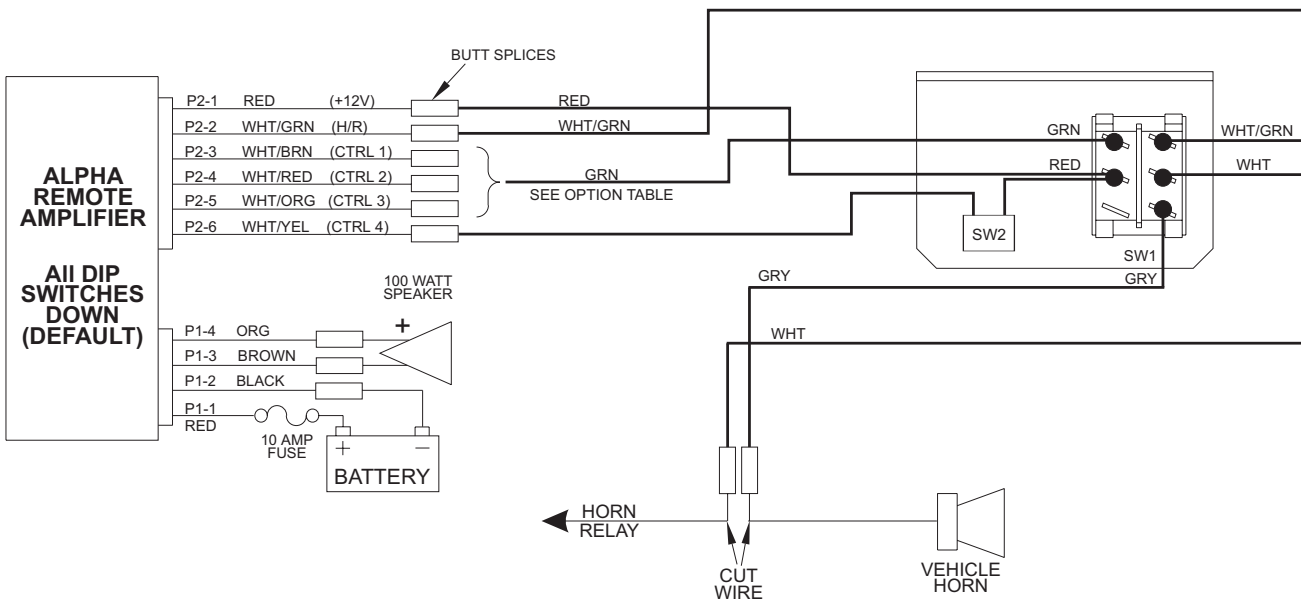

OPTION TABLE -SWITCH ASSEMBLY (Alpha 3)

Connecting the GREEN wire to the wire(s) below will enable the following specific siren tones in the "TONE 1" switch position of SW1:

- WHITE/BROWN = WAIL
- WHITE/RED = YELP
- WHITE/ORANGE = Hands Free

Connecting the VIOLET wire to the wire(s) below will enable the following specific siren tones in the "TONE 2" switch position of SW1:

- WHITE/BROWN = WAIL
- WHITE/RED = YELP
- WHITE/ORANGE = Hands Free

A simulated Air Horn tone is always available by pressing SW2.

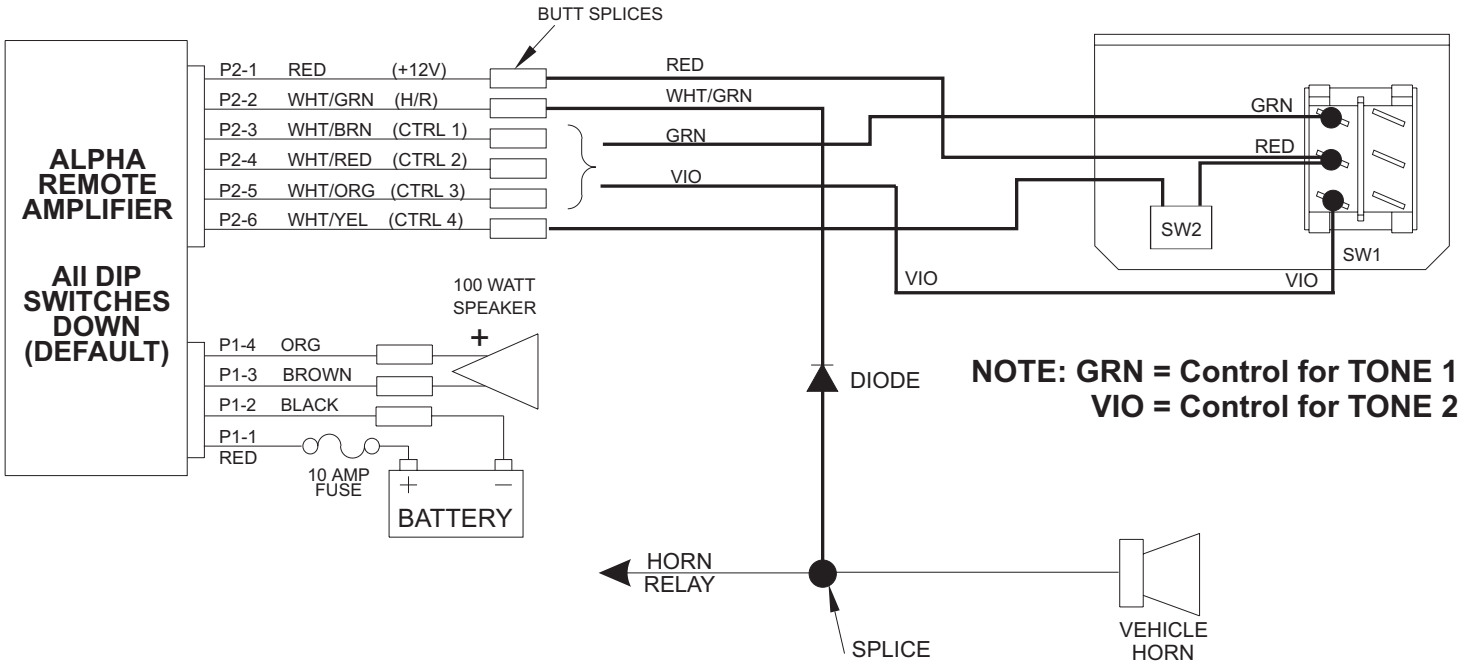

OPTION TABLE -SWITCH ASSEMBLY (Alpha 4)

Connecting the GREEN wire to the wire(s) below will enable the following specific siren tones in the "TONE 1" switch position of SW1:

- WHITE/BROWN = WAIL
- WHITE/RED = YELP
- WHITE/ORANGE = Hands Free

Connecting the VIOLET wire to the wire(s) below will enable the following specific siren tones in the "TONE 2" switch position of SW1:

- WHITE/BROWN = WAIL
- WHITE/RED = YELP
- WHITE/ORANGE = Hands Free

A simulated Air Horn tone is only available when SW1 is in the ON position. Activate via SW3.

